

## ② Power supply via FUHR switching power supply unit 12 V DC (residual ripple < 250 mVpp)

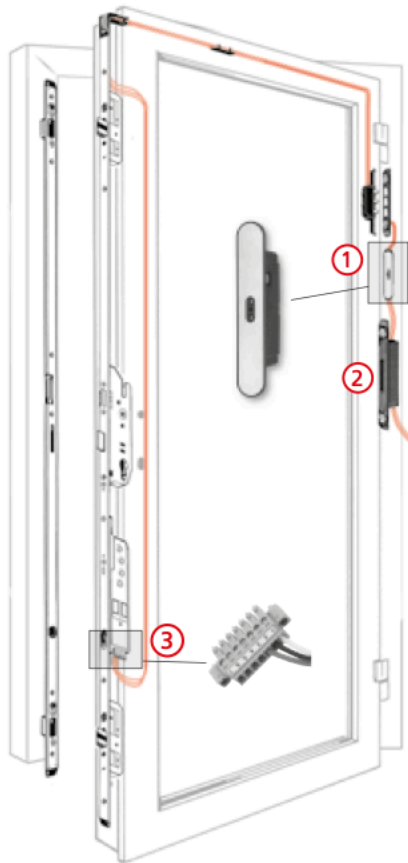

## ③ Control unit in the drive unit

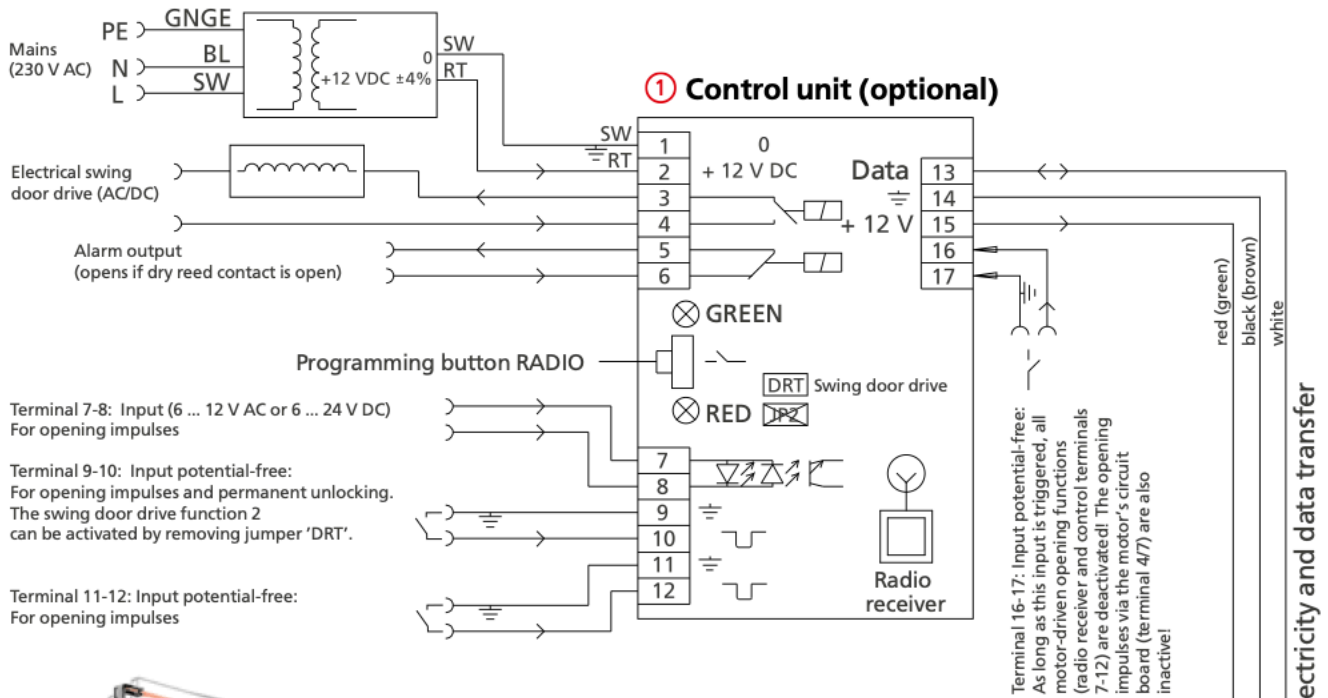
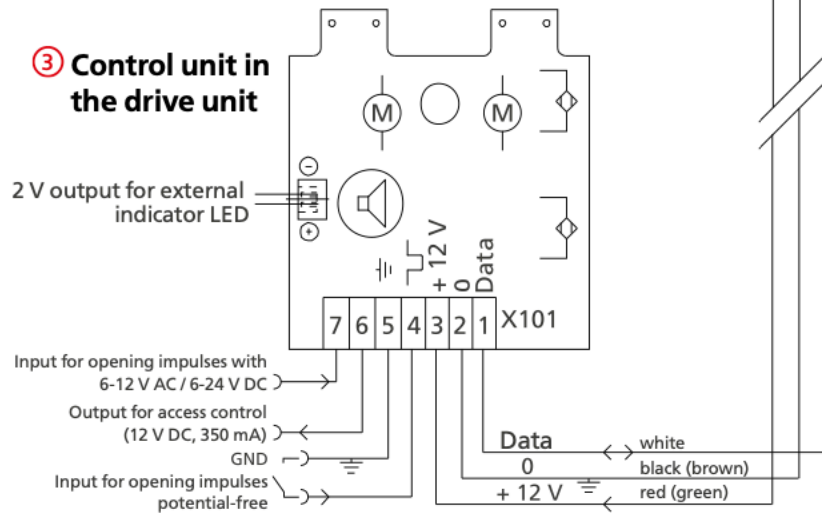

\*Wiring diagram valid for **autotronic 834** and **autotronic 836**.